

PARAPET CAP

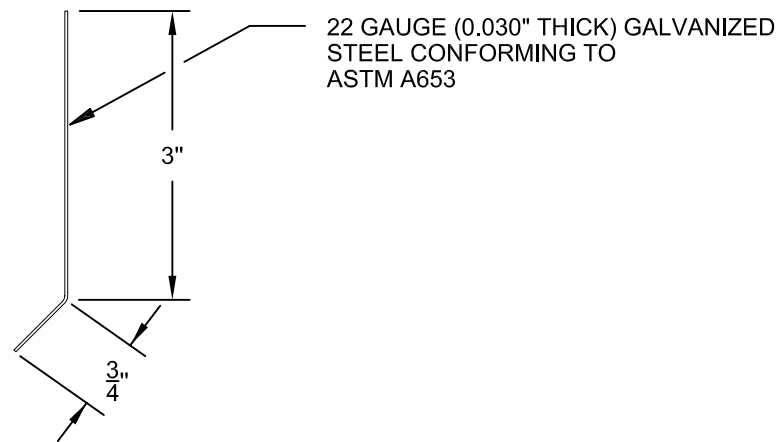

CLEAT

FABRICATION DRAWING

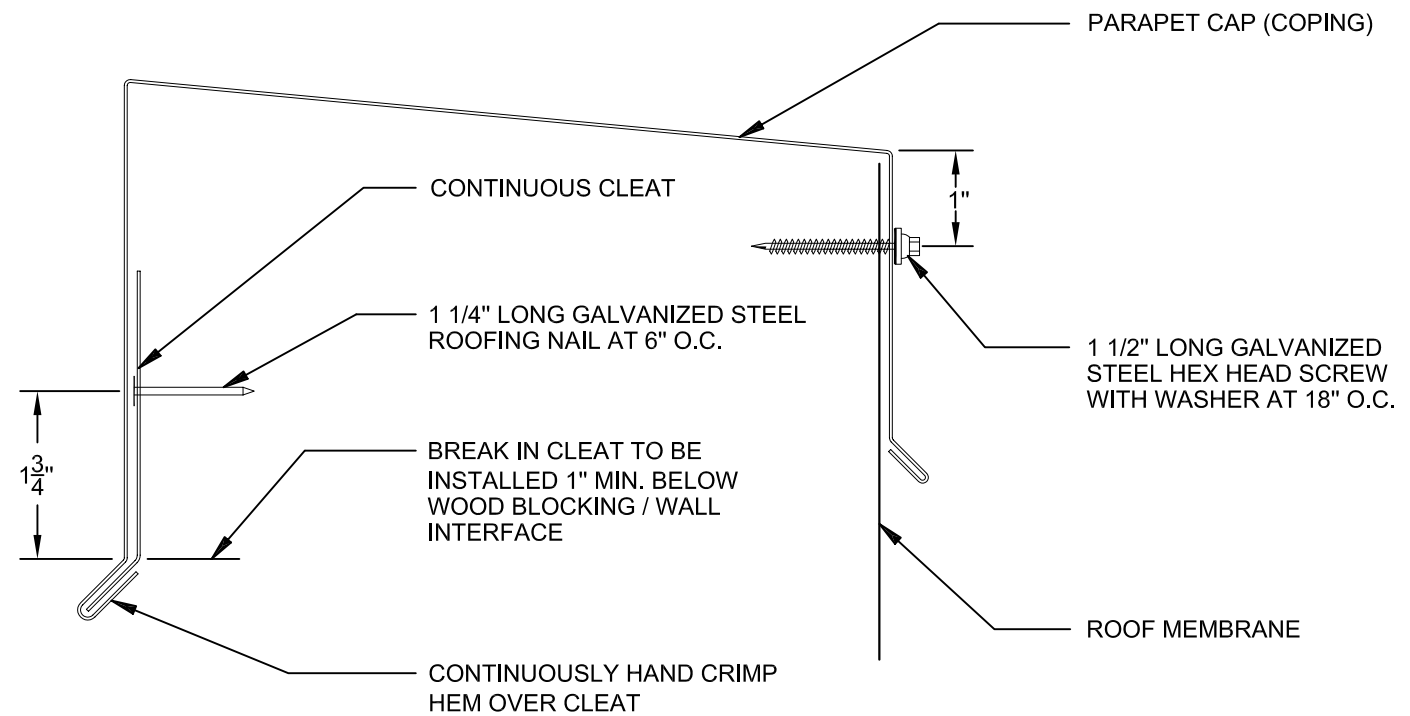

INSTALLATION DRAWING

DATE:  
6-1-01  
REV.:

Custom Metal Products  
2733 Vassar Place NE  
Albuquerque, NM 87107



RESISTANCE TESTED IN ACCORDANCE  
WITH ANSI/SPRI ES-1: 310 LBS/SQ. FT.  
ITS REPORT No. J99030617C-231

TITLE :  
24 GAUGE PARAPET CAP (COPING)

PER NRCA 5th EDITION CONSTRUCTION DETAILS:  
BUR-1, BUR-P-1, MB-1, MB-P-1, TP-1, TP-P-1, TS-1, TS-P-1, SPF-1

SHEET  
No:

05